

BIKE	YAMAHA YZF 600 R6	PART NO.	YA-1000
YEAR	2006 - Current	FIT KITS	Z039.10390
NOTES		FEATURES	DB KILLER Z028.20129 (U)

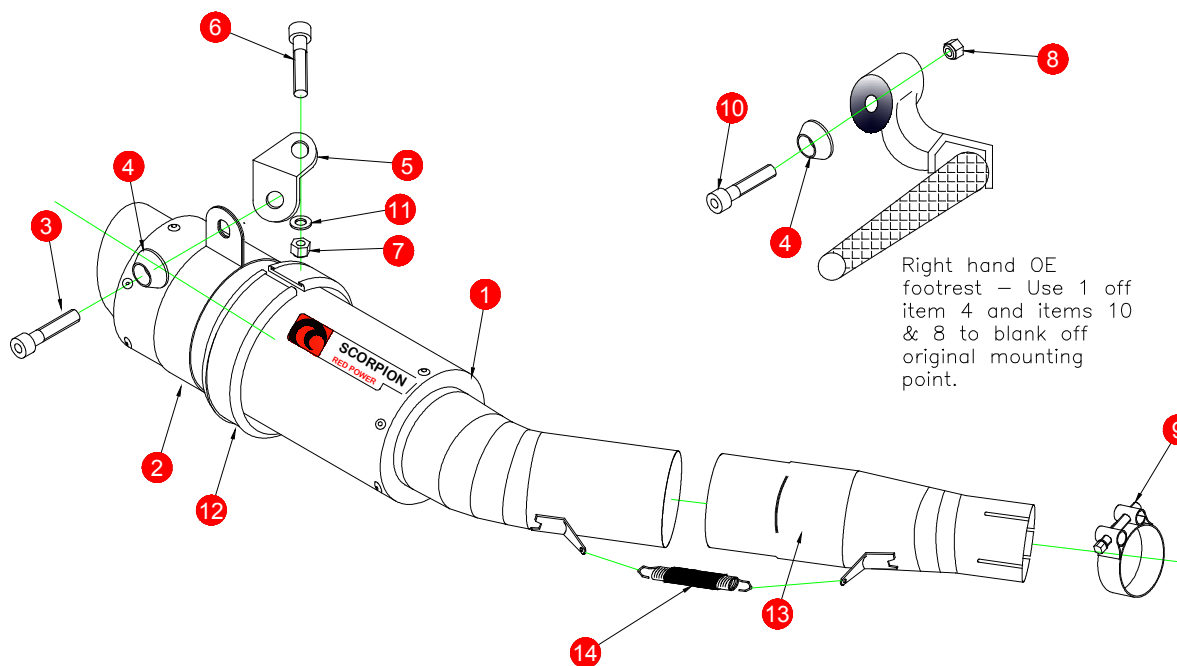

Right hand OE footrest – Use 1 off item 4 and items 10 & 8 to blank off original mounting point.

- | | |
|---|---------------------------------------|
| 1 225mm RP-1 GP Silencer with integrated CP 582 | 9 47-51mm Band Clamp (Z016.10003) |
| 2 Titanium Silencer Strap (Z028.10013) | 10 M8x30mm Cap Head Bolt (Z017.10074) |
| 3 M8x12mm Cap Head Bolts (Z017.10070) | 11 M6 Washer (Z017.10617) |
| 4 2 off Bolt Finishers (Z026.20068) | 12 Square edge rubber (Z029.10024) |
| 5 Mounting Bracket (Z015.10080) | 13 Connecting Pipe CP838 |
| 6 M6x40mm Cap Head Bolt (Z017.10022) | 14 Rubber Coated Spring (Z028.10030) |
| 7 M6 Nyloc Nut (Z017.10033) | 15 100mm Cable Tie (Z017.12732) |
| 8 M8 Nyloc Nut (Z017.10062) | |

E-MARK	BSAU 193a 1990/t3
ISSUE NO.	6
DATE	12/02/15
AUTHORISED	T.ROWLEY
CHECKED	

NOTE: ENSURE SCORPION SYSTEM IS CLEAR OF MOVING PARTS AND ALL ORIGINAL FUNCTIONS WORK CORRECTLY.



A) Remove original exhaust from bike, taking care to keep all original components in a safe place.

B) Refit Scorpion exhaust as per line diagram above.

C) When fitted take bike for a short ride to ensure all functions are correct.

D) When bike & exhaust are cool enough check all nuts and bolts are still secure.

Box: PLOCK 2

BIKE	YAMAHA YZF 600 R6	PART NO.	YA-1000
YEAR	2006 - Current	FIT KITS	Z039.10390
NOTES		FEATURES	DB KILLER Z028.20129 (U)

CONTINUED FROM OVERLEAF:



A) Remove lower fairing bolt to aid access to OE silencer clamp

B) Remove the three bolts shown to expose the exup valve & cables

C) Disconnect the cables by unscrewing the adjusting nuts & lift the nipples out of the wheel

You can now remove the OE silencer by removing the clamp & top hanging bolt

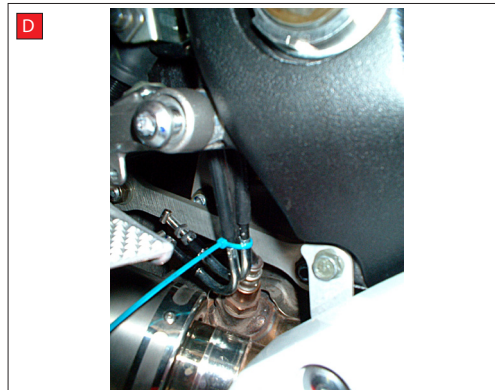
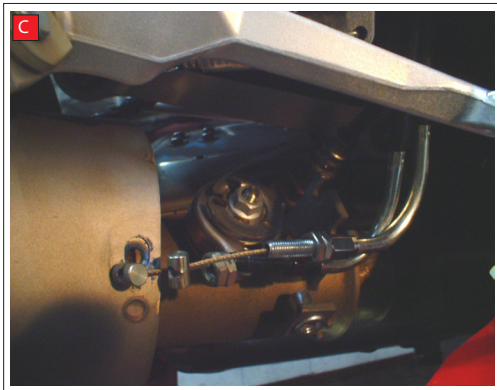

D) Before fitting the Scorpion silencer, use the cable-tie to safely attach the loose cables to the lambda sensor wire & trim the cable-tie.

E) Now remove the O.E flare and gasket from the exhaust to Scorpion product can fit the O.E.

F) Fit the Scorpion silencer with the new clamp & bolt and fasten securely with the Nyloc nut, then tighten the clamp. As shown in the line diagram.



Ensure all cables and any fitments are secured safely and all original functions work correctly prior to use.